

**MOTOR CYLINDER**  
**INTRUCTION MANUAL**  
**MS1K~MS1T, M1K~M50T**



**SEG** Shin Hwa Eng Co., Ltd

---

## Contents

1	Product Description .....	4
1-1	General .....	4
(1)	Introduction .....	4
(2)	Inspection and checks.....	4
1-2	Operation principle .....	4
1-3	Motor cylinder used.....	4
1-4	Specifications.....	5
1-5	Nomenclature.....	6
2	Product installation.....	7
2-1	Structures .....	7
(1)	MS Type.....	7
(2)	M(D, L, M, H) Type.....	8
(3)	Position of Limit Switch .....	9
(4)	Potentiometer Type.....	10
2-2	INSTALLATION .....	11
(1)	Storage .....	11
(2)	Installation Place.....	11
(3)	Installation Method.....	11
(4)	Piston rod Installation.....	12
(5)	Bellows Attaching .....	13
(6)	Stroke Setting .....	14
(7)	Cautions.....	14
(8)	Brake structure and manual operation.....	15
2-3	ELECTRIC WIRING .....	16
(1)	Wiring method.....	16
(2)	Limit Switch Circuit Diagram (For Overload).....	16
(3)	Position control .....	17
(4)	Cam switch Setting method.....	17
(5)	Basic Operation Circuit Diagram (Standard Type).....	18
3	CAUTIONS BEFORE RUN .....	19
3-1	Cautions before operating .....	19
(1)	Power phase .....	19
(2)	Proper connection with Machine .....	19

---

(3) Overload .....	19
(4) Frequency in Use .....	19
3-2 MAINTENANCE .....	20
(1) Grease lubrication .....	20
(2) Overhaul. ....	20
(3) Lubrication Cycle to Screwed Shaft.....	20
(4) Recommendable Greases.....	20
(5) Lubrication to Screwed Shaft .....	20

## 1 Product Description

### 1-1 General

(1) Introduction

The Motor cylinder is completely enclosed structure, consisting of an overload safety device (automatic stroke setting) by actuation of a compression spring, a highly efficient lead screw, a fully closed type motor combined with a precision reduction gear unit.

Therefore, careful handling of the Motor cylinder is necessary.

(2) Inspection and checks

- Does the nameplate match the order?
- Is there any damage during transportation?
- Are all tightening bolts fastened with sufficient force?
- In case there are any troubles, please check the model, serial number, situation and contact us immediately.

### 1-2 Operation principle

- The screw shaft rotates by the rotation of the motor.

At this time, the Piston rod assembled with the nut operates a linear restraining motion within the set stroke range, and the load reciprocates in forward and reverse rotation of the motor.

According to type, the required movement speed can be obtained by adjusting the pitch of the screw and the reduction ratio of the reduction gear device.

### 1-3 Motor cylinder used

(1) Used for elevating and lowering, reciprocating, compression and traction by linear motion

(2) Compressing Stop

It can also be used for devices requiring continuous compressive force or pulling force by the operation of a built-in spring, and can be safely stopped without mechanical overload by the operation of the spring and the limit switch.

(3) Retaining Load

When the load is applied even after Motor cylinder in operation is stopped, there are two ways in which the load from the stop position can be maintained.

First, the way to keep the screws locked on the brakeless type.

Second, the way of maintaining the load by the braking force by the brake attachment.

(Holding load  $\geq$  Applied load  $\times 1.2$ )

(4) Arbitrary Stroke Setting

In the type with an external or internal limit switch set, the stroke can be arbitrary set and used by adjusting the position of the limit switch operation cam within the entire stroke range.

(5) Inching Movement

When the Motor cylinder is installed or used, the inching movement on the stroke is also available for every of our products.

In the type with no brake, there is some difficulty in stopping at the correct position due to the inertia of the rotor inside the motor.

**1-4 Specifications**

Construction	: Totally enclosed outdoor type	Insulation Class	: B Class
Ambient Temperature	: -15°C~ 50°C	Rating	: 30min, 25% ED
Relative humidity	: 85% 이하	Brake	: Current
Power source	: 220 / 380 / 440V, 3Ph, 60Hz	Painted color	: Munsell 7.5BG 6/1.5

Thrust Load (kg)		100	300	500	1,000	2,000	4,000
Speed (mm/sec)	MS	146	55	42	42	-	-
	ML	15	15	13	13	13	26
	MM	35	41	42	42	36	35
Motor Power (kW)	MS	0.2	0.2	0.4	0.75	-	-
	ML	0.2	0.2	0.2	0.4	0.75	1.5
	MM	0.2	0.2	0.4	0.75	1.5	2.2
Stroke (mm)		200 ~ 600		200 ~ 1,000		200 ~ 1,500	

Thrust Load (kg)		6,000	8,000	10,000	13,000	16,000	20,000
Speed (mm/sec)	ML	18	15	12	12	10	15
	MM	30	36	30	36	30	20
Motor Power (kW)	ML	1.5	1.5	1.5	2.2	2.2	3.7
	MM	2.2	3.7	3.7	5.5	5.5	5.5
Stroke (mm)		300 ~ 3,000					

1-5 Nomenclature

M	L	A	1	T	-	0	6	J	P	L	C	N
↓	↓	↓	↓			↓		↓	↓	↓	↓	↓
①	②	③	④			⑤		⑥	⑦	⑧	⑨	⑩
①	Item		M - Motor Cylinder									
②	Speed		L - Low M - Medium H - High D - Damper Position Control S - Straight									
③	Screw		A - Acme Screw B - Ball Screw									
④	Rated Thrust load		5K-500kg, 1T - 1000kg									
⑤	Stroke		01 = 100mm, 10 = 1000mm									
⑥	Bellows		With - J, Without - None									
⑦	Potentiometer		With - P, Without - None									
⑧	Limit Switch		L - In Door, T - Out Door									
⑨	Installation method		C - Column, K - Clevis									
⑩	Specification		O - Standard, N - Special									

## 2 Product installation

### 2-1 Structures

#### (1) MS Type

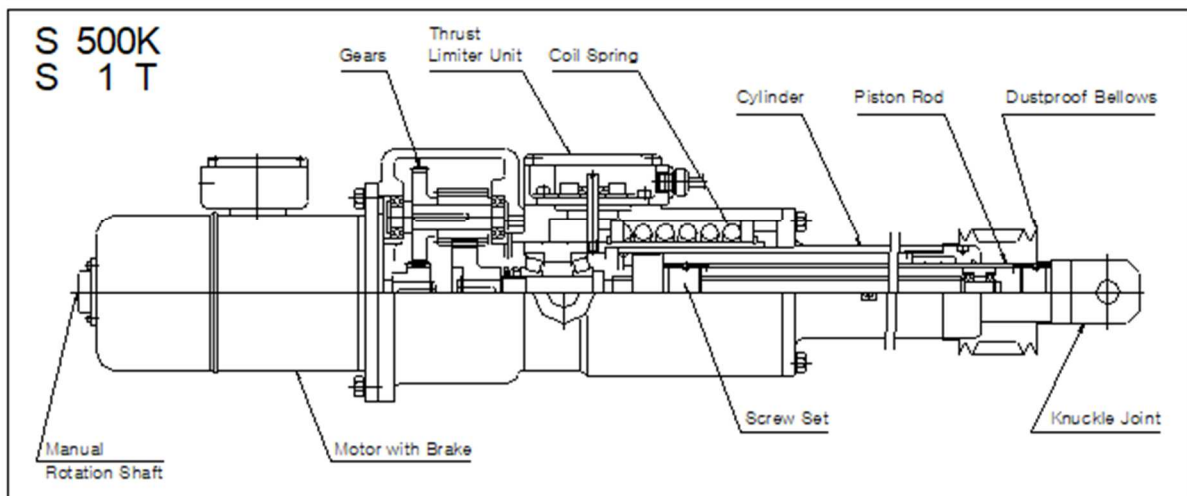
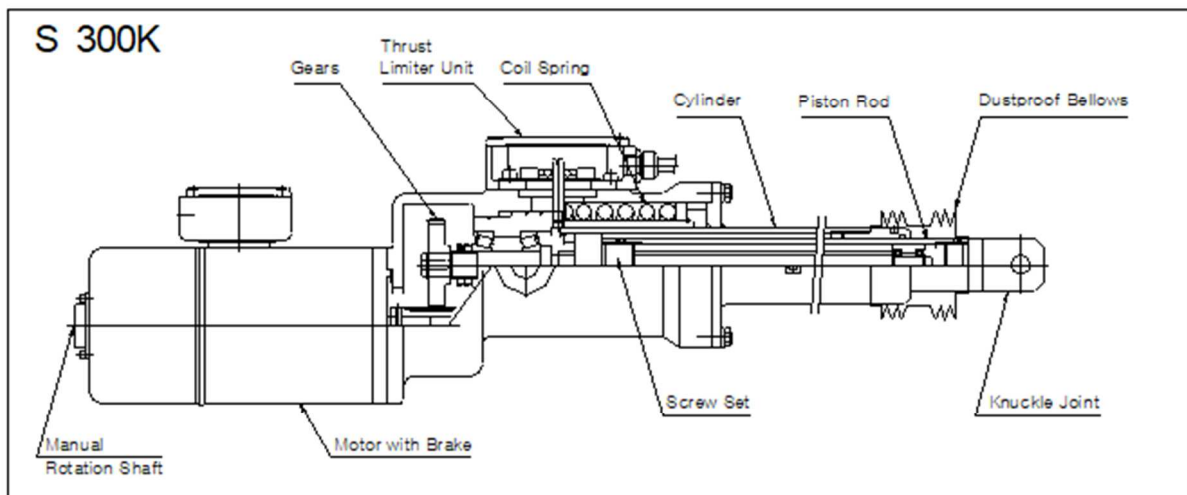
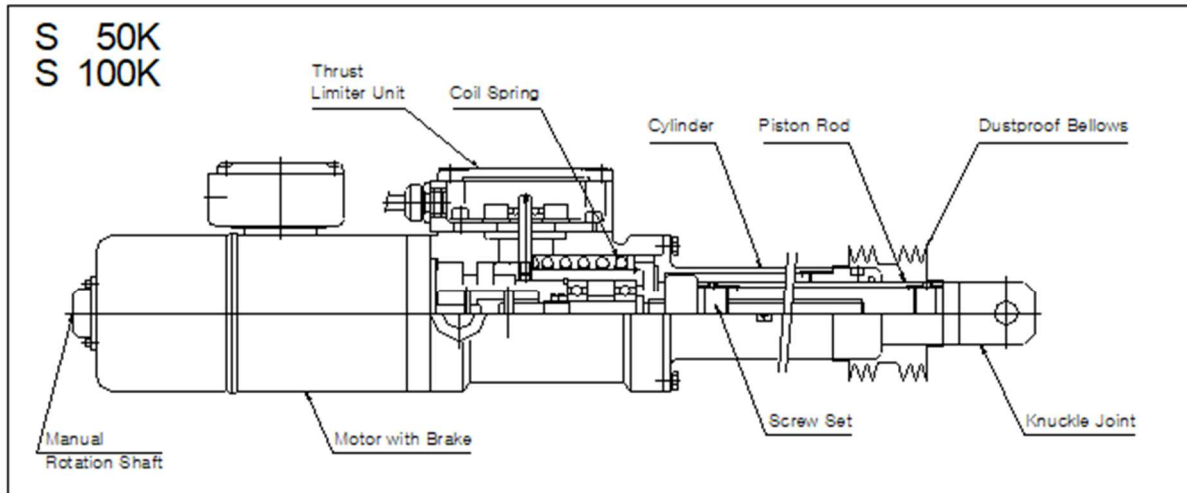

(2) M(D, L, M, H) Type

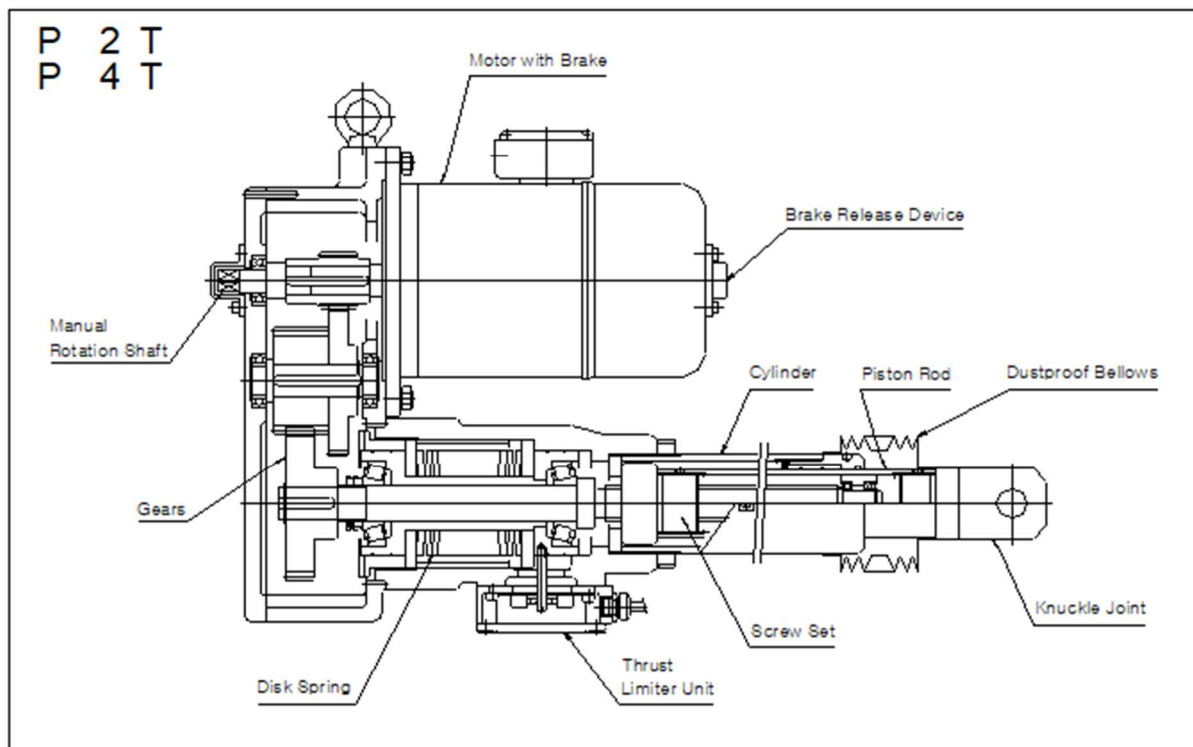
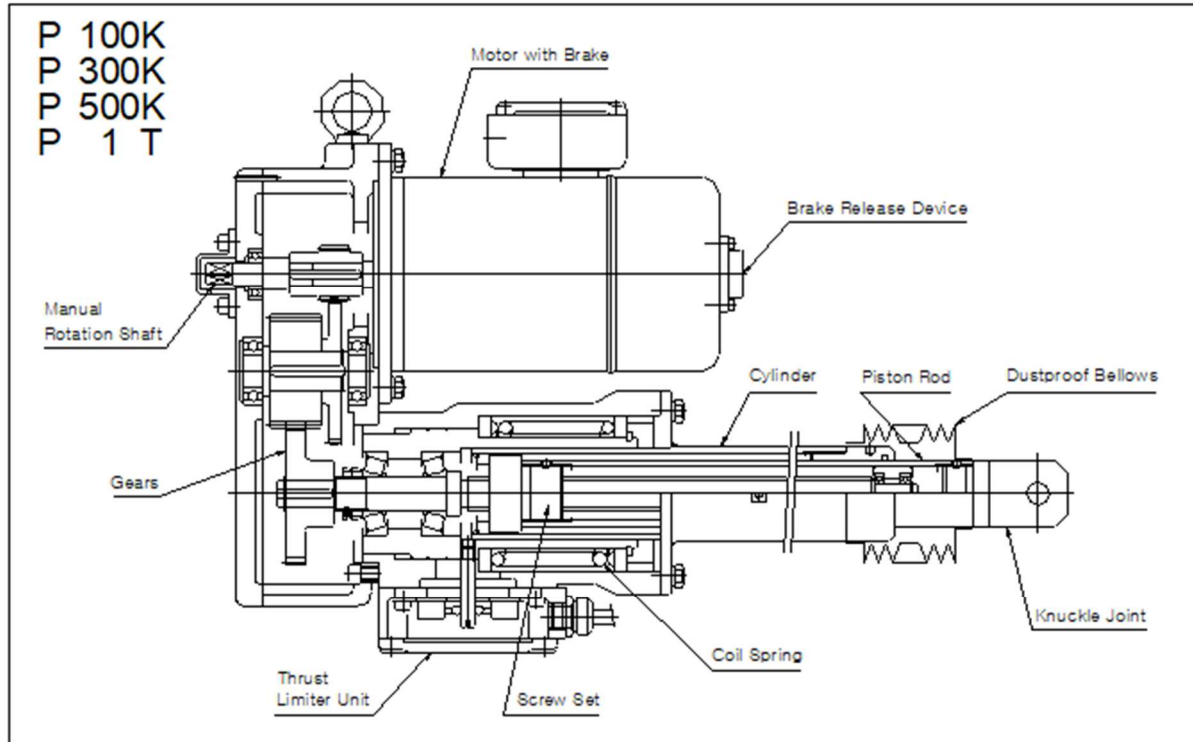



(3) Position of Limit Switch

① Internal limit switch type

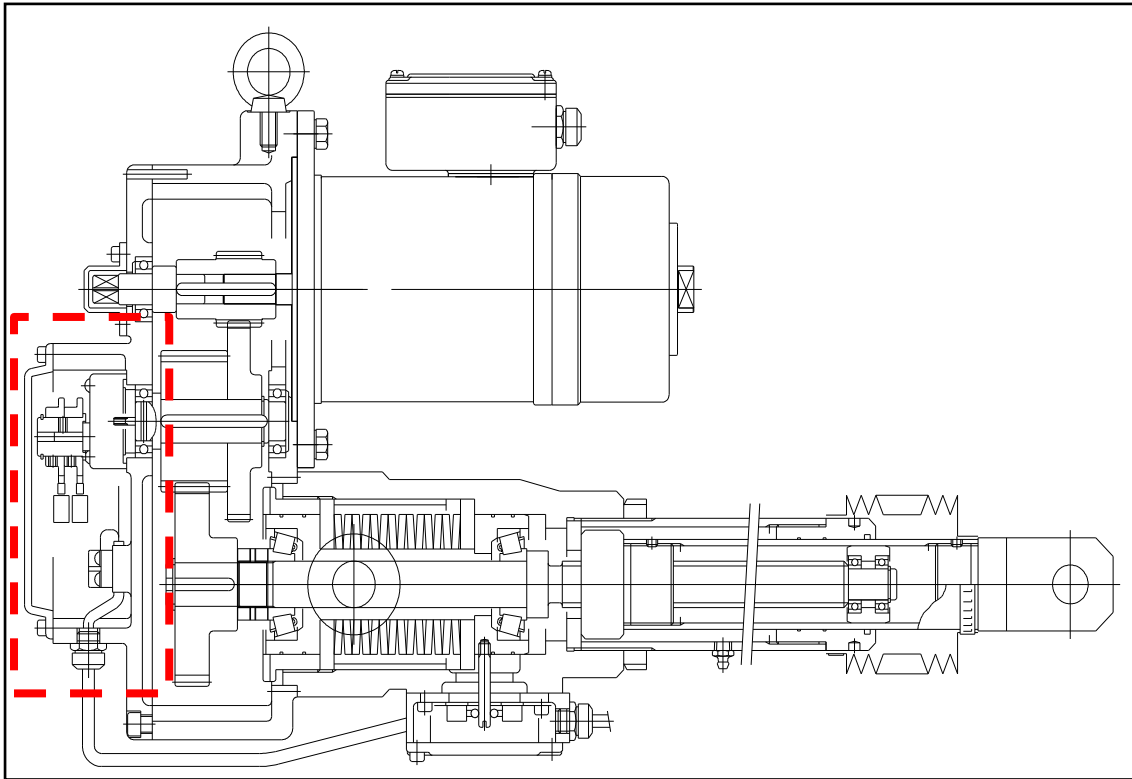

② External limit switch type

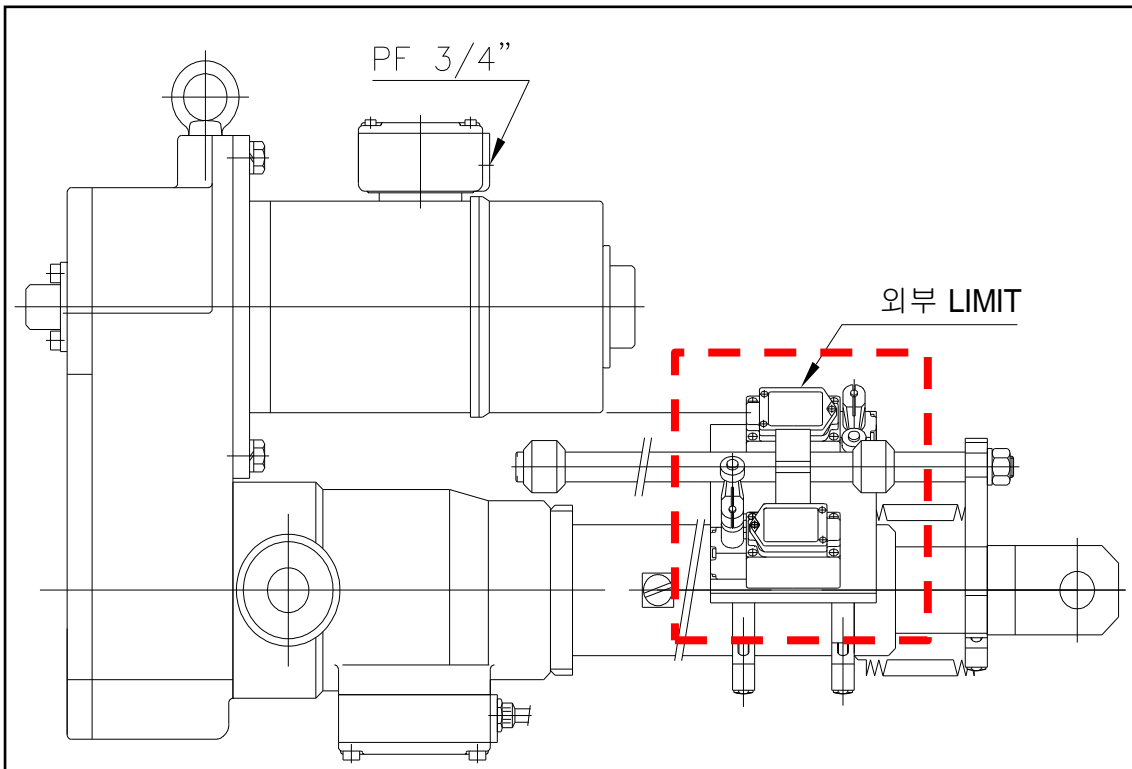

(4) Potentiometer Type

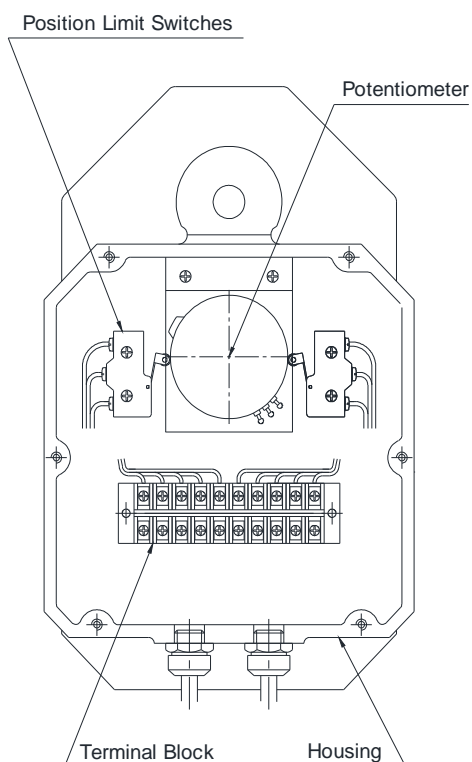
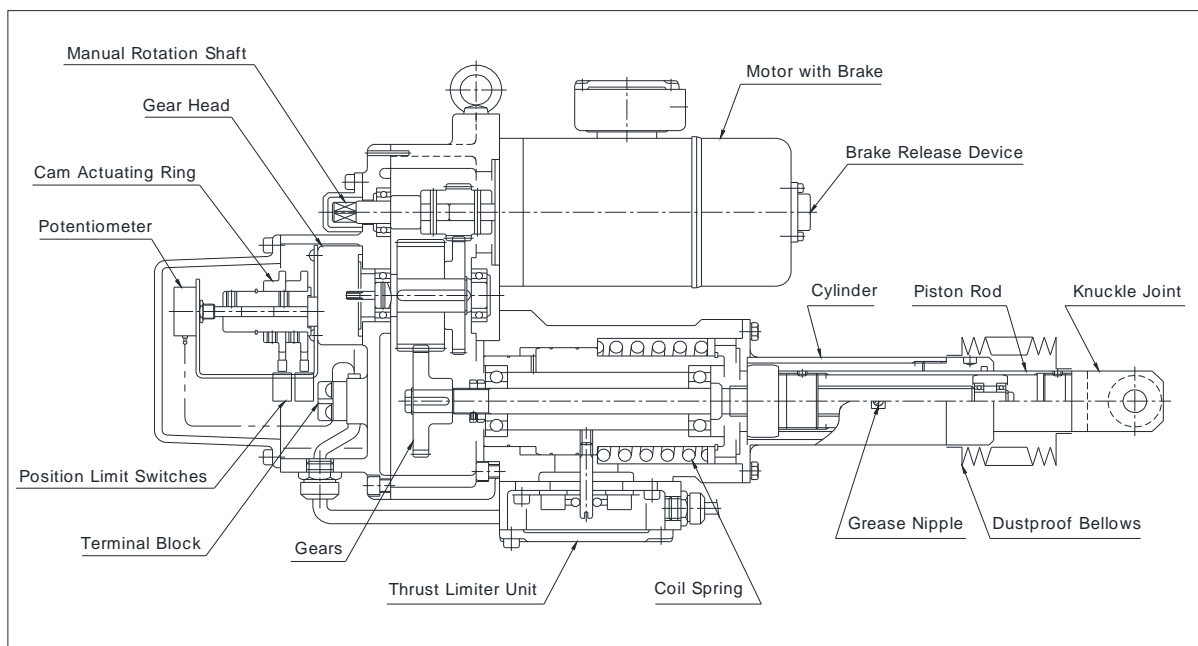

The P series was developed for precise position control of the damper and can also be used for compression suspension.

**Reduction Gears :** The standard product is configured as a two stage reduction gear. The high speed part uses a helical gear, and the low speed part uses a spur gear to ensure forward and reverse operation and sufficient life.

**Thrust Limiter Unit :** With the action of the compressed spring and limit switch, it can be safely stopped at any position in both directions in case of overload.

**Linear Safety Device :** It is a device that moves the rod in a straight line by the rotational force of the screw.

Since it is assembled firmly, it can be used without failure by periodic grease injection.

**Position Control Device :** The open / close angle signal is detected by the rotation of the potentiometer, and the combined cam can control the open / close position by operating the limit switch.

## 2-2 INSTALLATION

### (1) Storage

- Motor cylinders should be stored indoors.
- If the Motor cylinder is installed in a machine, it should be protected so that it can be protected from moisture, rain, dust, etc.

### (2) Installation Place

- It can be applied to all places as a fully enclosed structure, but should be protected from water, vapor, oil, etc. by attaching an appropriate cover.
- The insulation grade of the standard motor is B type.  
The insulation rating of the Motor cylinder is sure to confirm the temperature limit for each type.
- The operating temperature range is  $-15^{\circ}\text{C}$  to  $50^{\circ}\text{C}$ . When using it at higher temperatures, a heat dissipating cover must be attached.
- Outdoor type with Bellows is recommendable for use in bad atmospheres.
- If you install it outdoors, tighten the terminal box cover and the conduit connection cable completely after the electrical connection.  
And make sure that rainwater, moisture, and dust do not enter after tightening.

### (3) Installation Method

- It can be installed in either horizontal or vertical direction.
- We recommend Trunnion or Clevis Mounts as shown below figure.
- Flange or Foot Mounts do not allow lateral loads on the Cylinder rod.

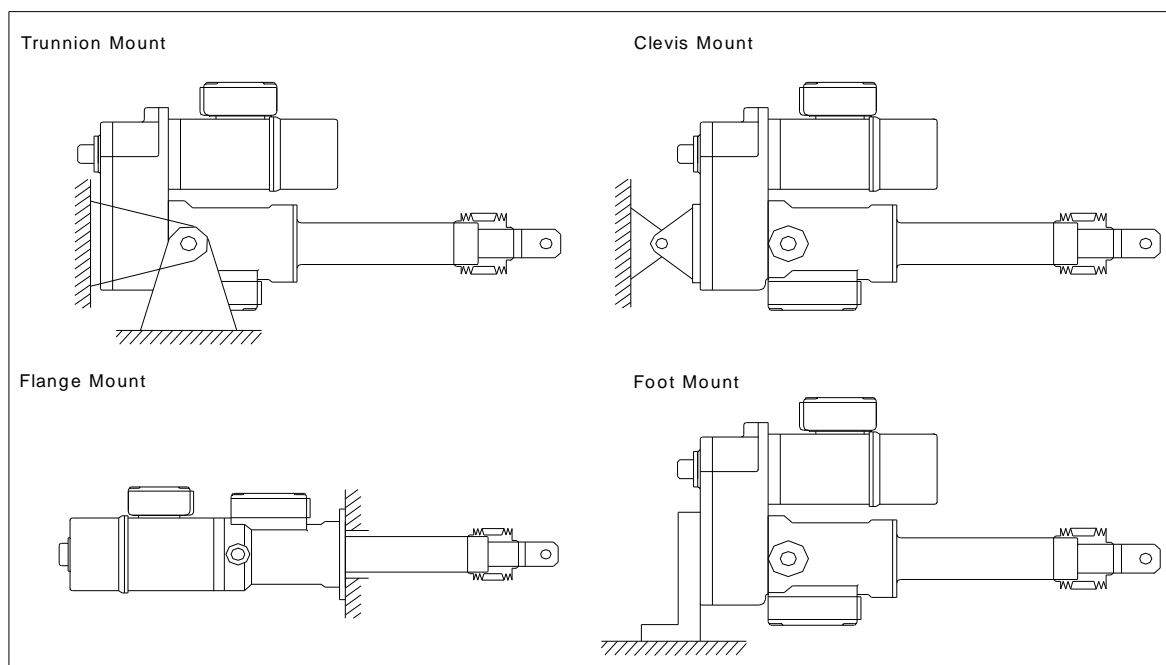

(4) Piston rod Installation

Rotation force of the Piston rod occurs during operation as follows

Model	Piston rod Torque(kg-m)	Model	Piston rod	Model	Piston rod Torque(kg-m)
			Torque(kg-m)		
M1K	0.3	M4T	10	M16T	33
M3K	0.8	M6T	12	M20T	54
M5K	1.6	M8T	18	M30T	54
M1T	3.5	M10T	19		
M2T	8	M13T	20		

- Since the standard product is not supplied with the prevent rotation device of the Piston rod, prevent rotation device should be attached to the product at installation.
- And when the Motor cylinder is operated in the unattached state, the Piston rod rotates and the fixed Bellows is damaged.
- There are two ways to manually adjust the stroke when installing, by turning the manual handle shaft and adjusting the Piston rod.
- The Piston rod reciprocates according to the rotation direction.  
If the Bellows is attached, make sure that the Bellows fixing band is released before moving the Piston rod and that it can be moved freely.  
If manually adjusting the stroke, the limit switch cam for position control must be readjusted.
- Operation power supply should never be supplied during manual adjustment

(5) Bellows Attaching

The Bellows is fixed to the end of the Piston rod. Attaching and replacing Bellows can be carried out in accordance with the following procedure while the Motor cylinder is connected to the machine.

- ① After connecting to the machine, the Bellows completely fasten the axis of the Piston rod
- ② Move the Piston rod to end of the Piston rod by manual or electric operation
- ③ At this time, the Bellows will be shrunk, so the cylinder side is fixed with a band. Then with the Bellows shrunk, clamp the band on the Piston rod side. Fitting the Bellows shrunk too much may cause its breaking
- ④ Unscrew the Set Screw with a L-wrench and disassemble the Knuckle joint (Fig-1)
- ⑤ After putting new Bellows, tighten the Knuckle Joint and Set Screw. (Fig-2)
- ⑥ Clamp with a band. (Fig-3)

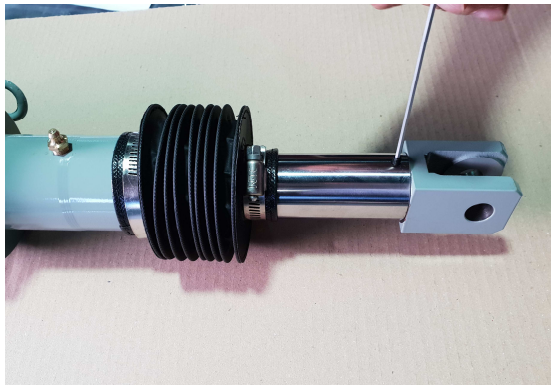

Fig.1 Attaching Bellows

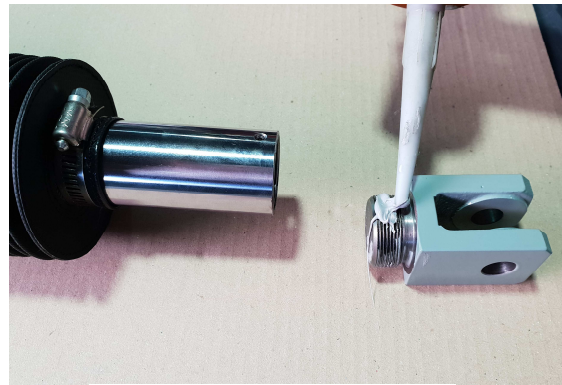

Fig.2 Attaching Bellows

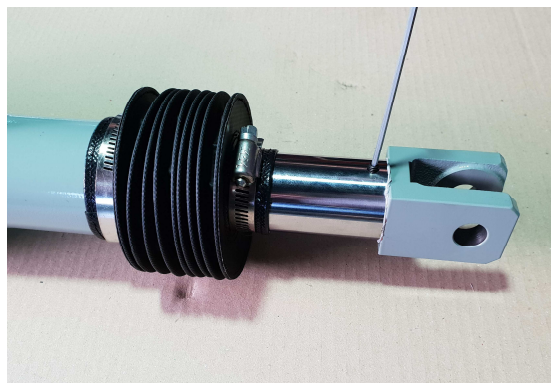

Fig.2 Attaching Bellows



Fig.3 Attaching Bellows

## (6) Stroke Setting

## - ON-OFF Operation

When using the motor cylinder only for reciprocation without stopping at the stroke midway point, an internal overload safety device can be used as a stopping function without a separate external limit switch.

In this case, it is applied to the opening and closing of the damper or the hopper and stops by pushing at the end of the stroke before and after the stroke.

Therefore, the stiffness of the stopper and the related part should be three times or more than the rated load.

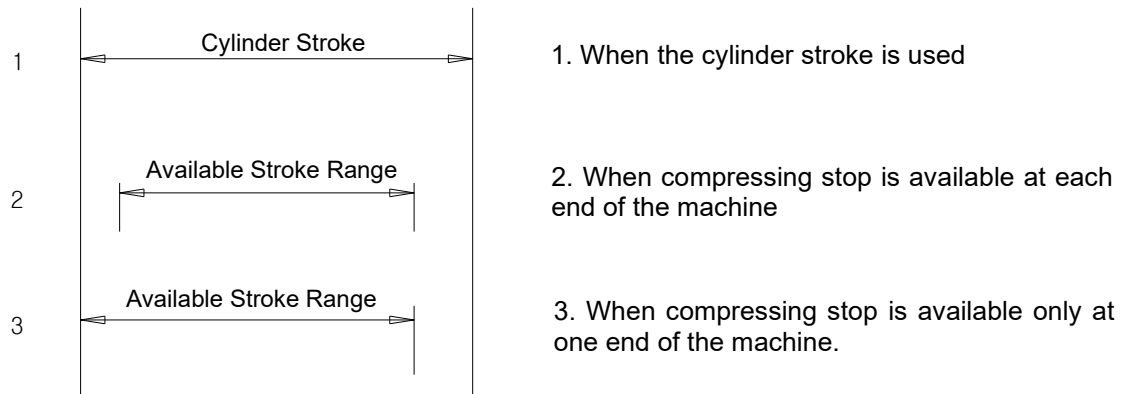

1. When the cylinder stroke is used

2. When compressing stop is available at each end of the machine

3. When compressing stop is available only at one end of the machine.

## - External limit switch

Within the stroke range of the Motor cylinder, the heading direction can be stopped in both directions by the operation of the limit switch attached to the outside.

If the motor brake is not attached, it is difficult to accurately stop at a desired position due to the rotational inertia.

If the brake-attached type is used, the motor can be stopped at a more accurate position.

## (7) Cautions

The switch box of the thrust limiter unit and the wire connections have been completely tightened before shipment.

If they are loosened or disassembled at site, please completely tighten them.

If incomplete, water may come into them, causing an accident to be brought about

## (8) Brake structure and manual operation

## ① Structure

- This brake is a dry, non-excitation type and generates a braking force when cutting off the current.
- It is composed of a Yoke, a fixed plate, an Armature, a flange disk, etc. The coil spring in the Yoke pushes the armature strongly.

## ② Advantages

- Maintain emergency braking at power failure, keep stopped for a long time, prevention of falling of self-weight and prevention of coasting.
- No pulsating sound or shock, low frequency fricative sound.
- Due to the dry single plate structure, there is almost no drag torque, there is no loss of rotation and no heat generation.
- Rotation of the torque adjusting ring allows a wide range of braking torque to be set.

## ③ Operations

- The coil spring in the Yoke always pushes the armature when the power is cut off, and the flange disk is squeezed by the force based on the fixed plate, and the rotating part is braked by the frictional force.
- Conversely, when power is supplied to the electronic coil, the Armature is squeezed with a stronger force than the spring biasing force.
- Therefore, a space is formed between the flange ring and the Armature so that the rotating part can freely rotate.

## ④ Manual operations

- If the power is cut off and the brake is operating, remove the cover first and then turn the manual operation handle to the left by about 1.5 to make manual operation.
- Then, the snap ring brings the Armature into close contact with the Yoke, creating a gap between the flange disk and the Armature, and allowing the rotating part to rotate freely.
- When returning to the original state after completing the manual operation, reverse it in order.



SHINHWA Motor Brake

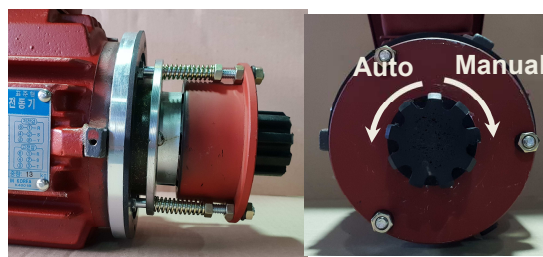

HIGEN Motor Brake

## 2-3 ELECTRIC WIRING

## (1) Wiring method

In wiring the Motor cylinder give special care to the following points

- Since the cylinder itself swings around the Trunnion shaft during operation, it is preferable to use flexible cable for wiring.
- When the outdoor type is installed, the motor and the brake terminal box can be assembled by rotating them by 90 degrees, so that it is preferable that the electric wire outlet is installed downward.
- In principle, it is not recommended to use flexible tube. If flexible tubes are unavoidably used, it should be completely watertight, but the connection part should be sealed with liquid packing (Three Bond No.2)

## (2) Limit Switch Circuit Diagram (For Overload)

- Five-point Switch (Standard)
  - LSF Terminal 1-2 : Normally ON, but OFF for continuous pushing at the end of stroke and in case of overload while the Piston rod is extending.
  - LSF Terminal 1-4 : Normally OFF, and it is ON when overload continues (For signal check)
  - LSR Terminal 1-3 : Normally ON, but OFF for continuous drawing at the end of stroke in case of overload while the Piston rod is retracting.
  - LSR Terminal 1-5 : Normally OFF, and it is ON when overload continues. (For signal check)

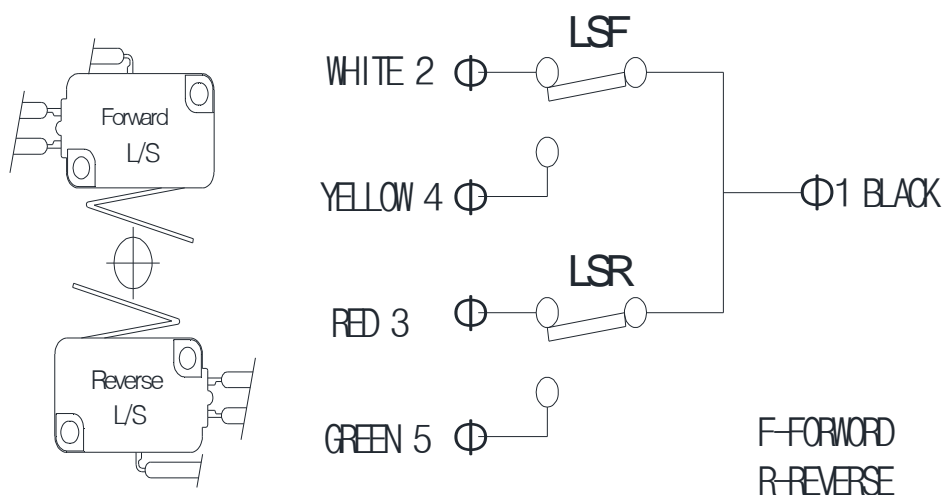



(3) Position control

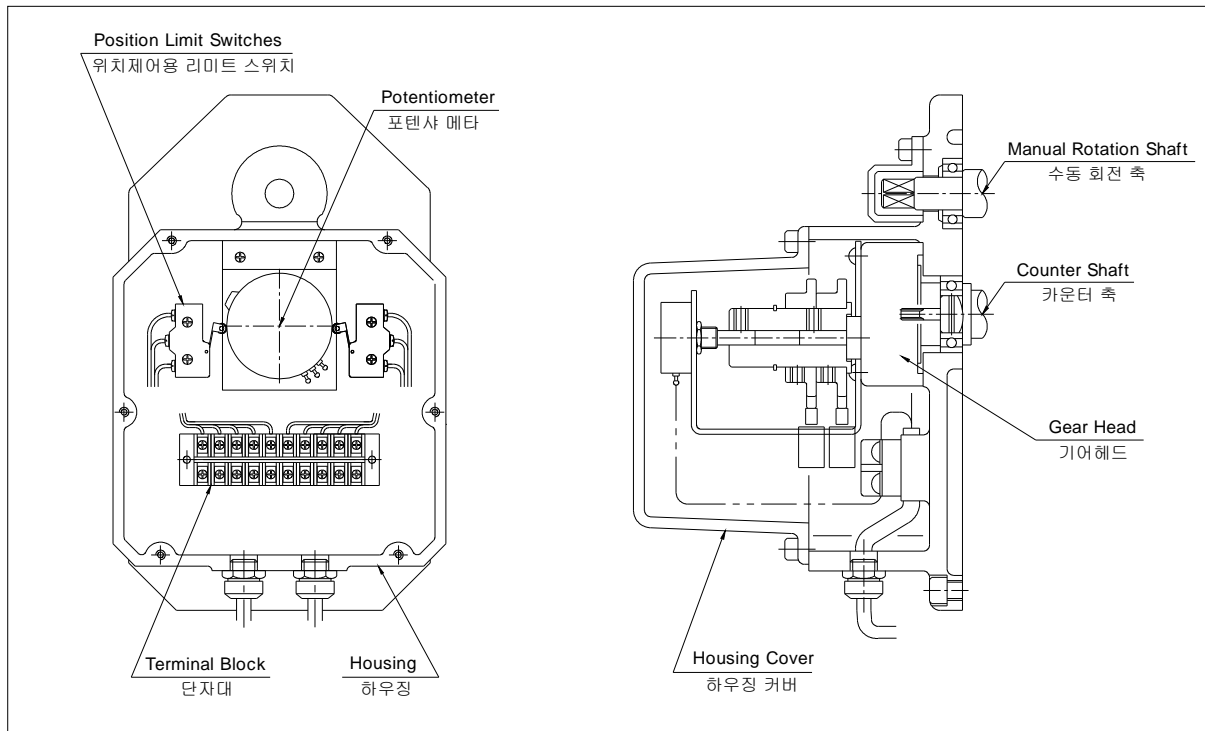

If a Gearhead(High speed reduction gearbox) is installed on the intermediate shaft of the Motor cylinder decelerator and the Piston rod is reciprocated by attaching a limit switch operating cam and a potentiometer to the output shaft, the output shaft will rotate forward and backward (within 300 ° rotation).

Then, the position detecting device detects the position.

(4) Cam switch Setting method

- Connect the main body of the Motor cylinder and the knuckle joint to the other machine and stop the Piston rod in the correct position while reciprocating the Piston rod to fix the two cams respectively.
- Be careful not to change the limit switches because the cam rotates forward and reverse at this time.
- Do not turn the Piston rod after adjustment.

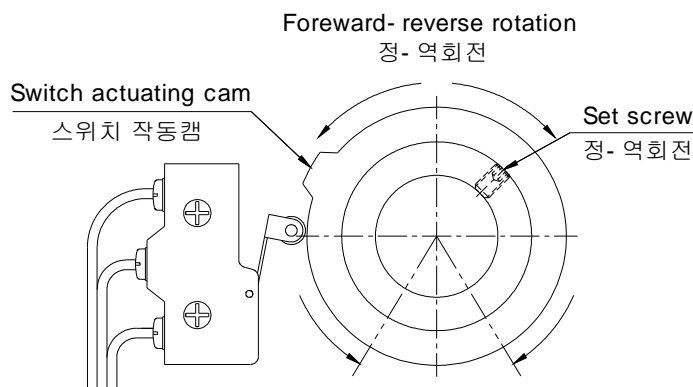

- If the Motor cylinder can be used with any stroke by adjustment of the Positioning limit switch operation cam, it can be used in the entire stroke range by the operation of the overload safety device

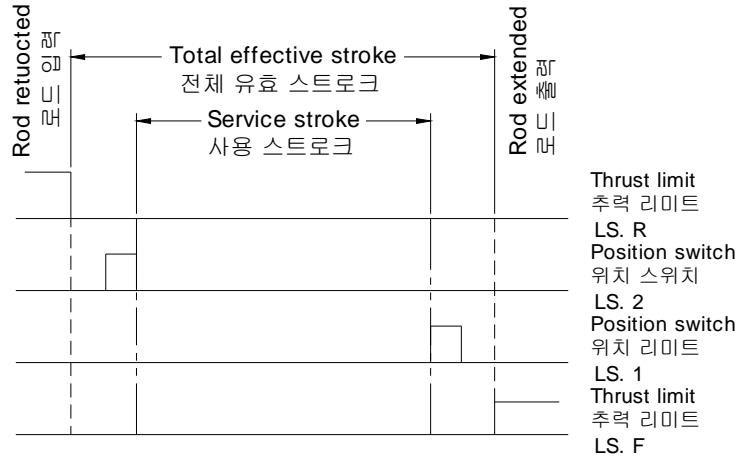

(5) Basic Operation Circuit Diagram (Standard Type)

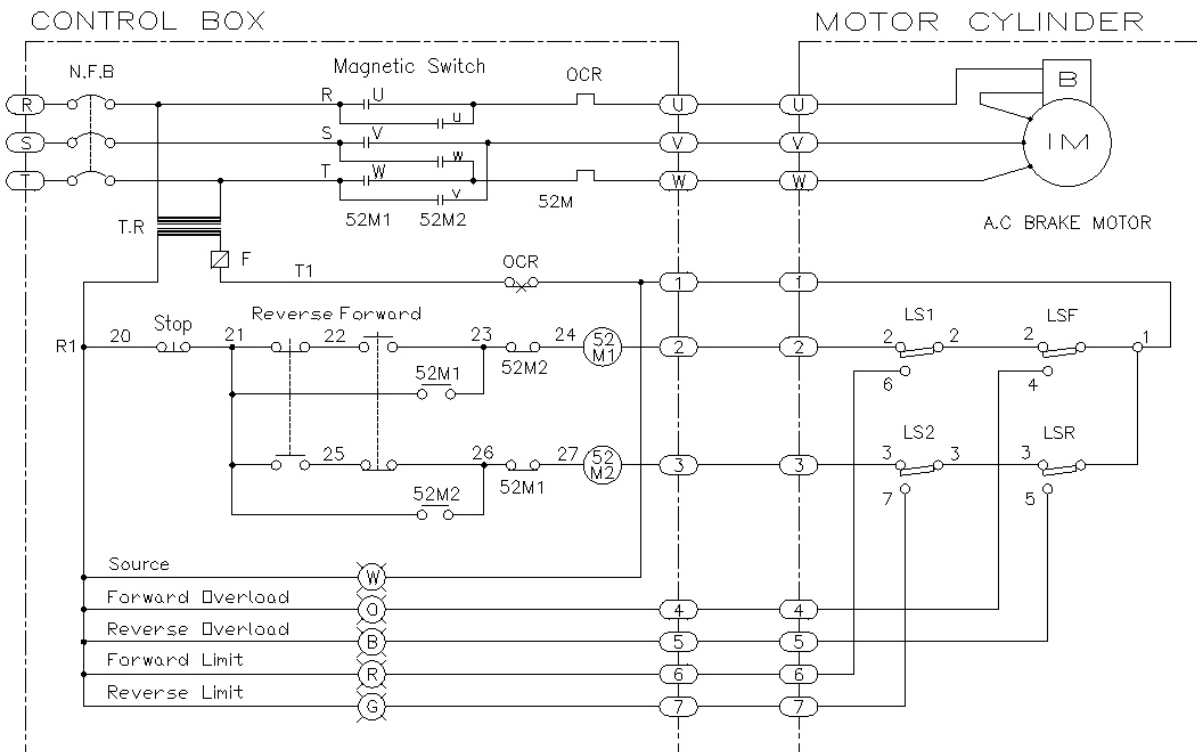

- The basic circuit diagram of the Motor cylinder is shown below. Various kinds of controls are available by using an external command switch or a push button as an operational switch depending upon desired operations.
- When the PBF switch is ON, the Piston rod moves forward, and when it is turned OFF, it stops. When the PBR switch is turned ON, the Piston rod will move backward, and if it is turned OFF, the Piston rod will stop.

### 3 CAUTIONS BEFORE RUN

#### 3-1 Cautions before operating

(1) Power phase

Inch the operational switch to make sure if the Piston rod moves normally.

In case the power phase is reverse, it will move in the opposite direction.

At this time, when the Piston rod reaches the end of the stroke by supplying power to the motor continuously, the overload safety device does not work and the motor is burned out. Therefore, immediately switch it off and replace two of the three wires on the power side.

(2) Proper connection with Machine

Check if the side load is applied to the Piston rod.

If it acts, it will cause damage such as wear of the rod.

Please check whether it is connected to the machine part or excessive load is applied.

(3) Overload

When the Motor cylinder is used, if a load has reached the limit or the large inertia body is moved, the overload device may be activated when the motor starts. In this case, reduce the load.

(4) Frequency in Use

The heat capacity of the motor cylinder is well afforded.

However, the operational frequency will be limited because of its reciprocating movement. Calculate the tolerable operational frequency by using the following equation and table:

$$\text{Loading time (\% ED)} = \frac{\text{Running time in one cycle}}{\text{Running time in one cycle} + \text{rest time}} \times 100\%$$

It is recommended to set it lower than the value shown in the chart below and the default waiting time is more than 30 seconds.

If you need to use continuously, please contact us.

Model	Loading time (%ED)	Operating times (times/min)	Model	Loading time (%ED)	Operating times (times/min)	Model	Loading time (%ED)	Operating times (times/min)
M1K	Less than 25%	5	M4T	Less than 25%	4	M16T	Less than 25%	3
M3K		5	M6T		3	M20T		2
M5K		5	M8T		3	M30T		2
M1T		5	M10T		3	-		-
M2T		4	M13T		3	-		-

3-2 MAINTENANCE

(1) Grease lubrication

Since our Motor cylinder is coated with good-quality grease before shipping, it can be used without additional lubrication.

For grease lubrication refer to the following table.

Lubrication points	Each grease supply(g)	Method
Screwed Shaft	10 ~ 30	Lubricating through the lubrication point in the middle of the cylinder with a grease gun
Gears Bearings	100 ~ 150	Application to the gears each two years or after 100 thousand times.
Sliding Bearings	50 ~ 100	Application to the surface each two years or at every routine inspection

(2) Overhaul

Overhaul should be made every two years of after 100 thousand times.

(3) Lubrication Cycle to Screwed Shaft

Operational frequency	Cycle
700 times or more / day	1 month
100-700 times / day	1 month to half a year
10-100 times / day	6 months to 1 year

(4) Recommendable Greases

Manufacturers	Product name
Mobll	Mobilux No.1
Shell	Alvania No. 1

(5) Lubrication to Screwed Shaft

- ① As shown in the figure, advance the Piston rod and inject an appropriate amount of grease into the grease gun.
- ② Then reciprocate the cylinder several times. Repeat this cycle three or four times.

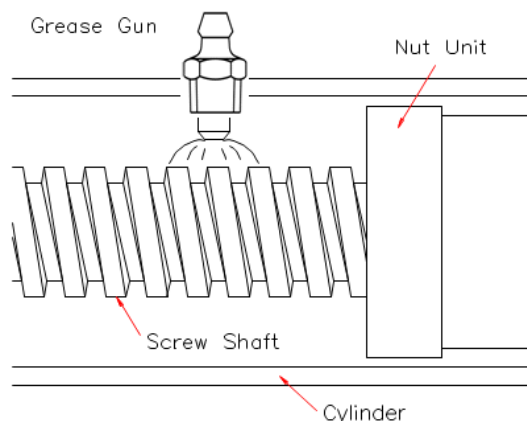

**SEG** SHINHWA ENG. Co., Ltd.

### Manufacturer information

Company Name : SHIN HWA ENG Co., Ltd

Address : 242 Cheongneungdae-ro ( 80B -2L ), Namdong gu,  
Incheon Korea

ZIP CODE : 21695

Tel : 82-32-817-8030

Fax : 82-32-815-8036

E mail : [8030@seg.co.kr](mailto:8030@seg.co.kr)

Website : <http://www.seg.co.kr>

COPYRIGHT 2020(C) Shin Hwa Eng Co., Ltd .ALL RIGHTS RESERVED